

Design and Control of a CSTR for Production of Ethyl Acetate

Salma Omer Alhag Ali¹, Maab Salah Mohamed² and Gurashi Adalla Gasmelseed³

^{1,2,3}Department of Chemical Engineering, Faculty of Engineering, University of Science and Technology, Sudan
¹salmaomer959@gmail.com, ²maabsalah28@gmail.com and ³gurashigasm@gmail.com

Publishing Date: March 04, 2017

Abstract

Ethyl acetate is produced by the reaction of ethanol and acetic acid in presence of sulphuric acid as a catalyst. The reaction is exothermic and the temperature of the reaction should be controlled at the desired value for optimum conditions. The level of the reactants and composition of the product should also be tightly controlled. A cascade control is used to control both the reaction and the jacket temperatures, so the rise in temperature will not affect the quality of the product. A control strategy was developed, the transfer functions were specified and use for simulation for each loop and selection of a controller that gives the best performance.

Keywords: Control Strategy, Design and Simulation, CSTR, Tuning, Control Loop, Cascade Control, Transfer Functions.

I. Introduction

Feedback control is the simplest type of control system for automatic process control that compensates for the process upsets. However, the disadvantage of feedback is that it only reacts after the process has been upset. Thus, a deviation on the controlled variable is needed to initiate corrective action. Cascade control is control system that in some applications significantly improves the performance provided by the feedback control. Cascade control is implemented in order to improve the disturbance rejection properties of the controlled system. The introduction and use of an additional sensor that allows for a separation of the fast and slow dynamics of the process results in a nested loop configuration, each loop has associated its corresponding controller. The fast dynamics of the inner loop will provide faster disturbance attenuation and minimize the possible effect of disturbance before they affect the primary output. This set up involves two controllers,

it is therefore needed to tune both PID controllers. The usual approach involves the tuning of the secondary controller while setting the primary controller in manual mode. On a second step, the primary controller is tuned by considering the secondary controller acting on the inner loop. It is therefore a more complicated design procedure than that of a standard single-loop based PID control system.[4]

II. Materials and Methods

Cascade Control

The system under consideration is an ideal CSTR with an exothermic reversible reaction; the liquid phase esterification of ethyl alcohol with acetic acid in the presence of sulphuric acid as a catalyst:

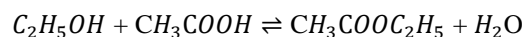

The dynamic of this process is highly non-linear mainly due to the heat generation process. Many reactors are inherently unstable, so an effective and well-designed control system is necessary in order to assure stable operation. The instability appears when reversible exothermic reactions are carried out in a CSTR. These reactions tend to produce a large increment in temperature, forcing the rupture of safety and reducing the life time of the reactor. The faster reaction goes, the more heat is generated, heating up the reaction mass, and consequently, raising the reactor temperature and increasing the rate of reaction. So under these conditions, the system can reach undesirable high temperature state. The solution to this problem is a temperature control system capable of detecting the rising of the reactor

temperature is affected by changes in disturbance variables such as reactant feed temperature or feed composition. The simple feedback control strategy would handle such disturbance by adjusting a control valve on the cooling water inlet.

However, an increase in the inlet cooling water temperature, an unmeasured disturbance, can cause unsatisfactory performance. The resulting increase in the reactor temperature, due to a reduction in heat removal rate, may occur slowly. If appreciable dynamic lags occur in the jacket as well as in the reactor, the corrective action taken by the controller could be delayed. To avoid this disadvantage, a feedback controller for the jacket temperature, whose set point is determined by the reactor temperature controller, can be added to provide cascade control. The control system measures the jacket temperature, compare it to a set point, and adjusts the cooling water makeup. The reactor temperature set point and

both measurements are used to adjust a single manipulated variable, the cooling water make up rate. The principal advantage of the cascade control strategy is that a second measured variable is located close to a potential disturbance and its associated feedback loop can react quickly. Thus, improving the closed-loop response.

A control strategy was developed, transfer functions have been identified and we control the temperature inside the reactor and jacket temperature by cascade loop as show in figure(1) ,and control the concentration of reactant (feed stream), also control the level inside the reactor. All loops had to be analyzed for stability and Tuning. By Routh - Hurwitz, Root Locus, Direct substitution, and Bode methods.

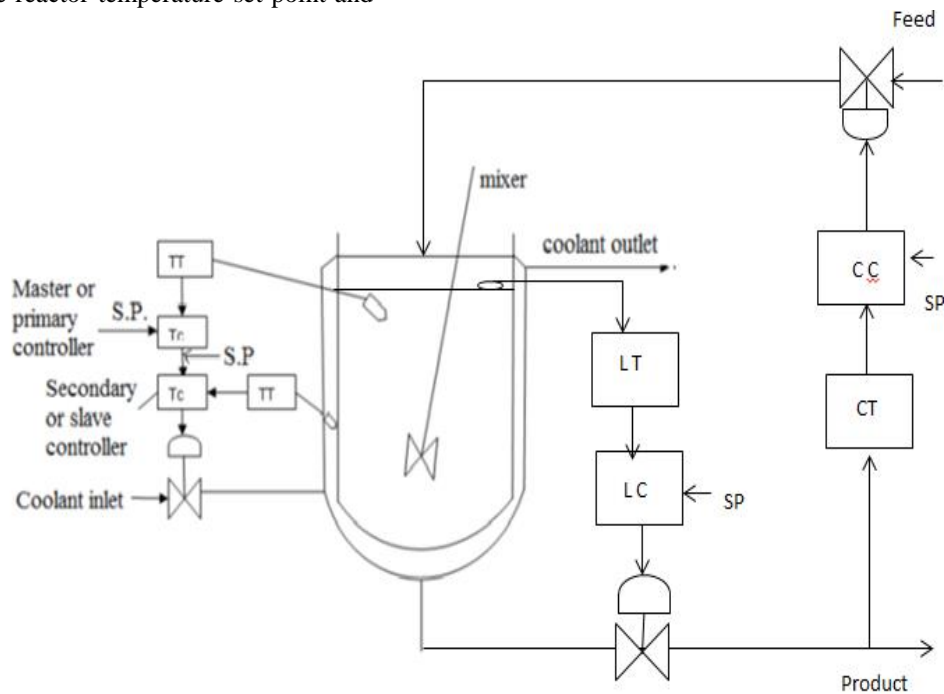

Figure 1: Control Strategy of CSTR reactor for Ethyl Acetate production

Identification of Transfer Functions of Control Loops

From the literature [3] the following transfer functions are obtained:

Loop1:

$$G_C = K_C$$

$$G_P = \frac{1}{(s+1)(4s+1)} \dots\dots\dots(1)$$

$$G_V = \frac{2.5}{0.2s^2+1.5s+1} \dots\dots\dots(2)$$

$$G_m = 1.0$$

Loop2:

$$G_C = K_C$$

$$G_P = \frac{1}{2s+1} \dots\dots\dots(3)$$

$$G_V = \frac{3.5}{2.5s^2+1.5s+1} \dots\dots\dots(4)$$

$$G_m = \frac{1.5}{0.2s+1} \dots\dots\dots(5)$$

Cascade Control Loops

$$G_{cI} = K_{cI} \dots\dots\dots(6)$$

$$G_{cII} = K_{cII} \dots\dots\dots(7)$$

$$G_{pI} = \frac{12.8}{16.7s+1} \dots\dots\dots(8)$$

$$G_{pII} = \frac{1.841}{0.917s+1} \dots\dots\dots(9)$$

$$G_V = \frac{6.6}{0.9s+1} \dots\dots\dots(10)$$

$$G_{mII} = \frac{1}{2s+1} \dots\dots\dots(11)$$

$$G_{mI} = 1.0 \dots\dots\dots(12)$$

Loop1:

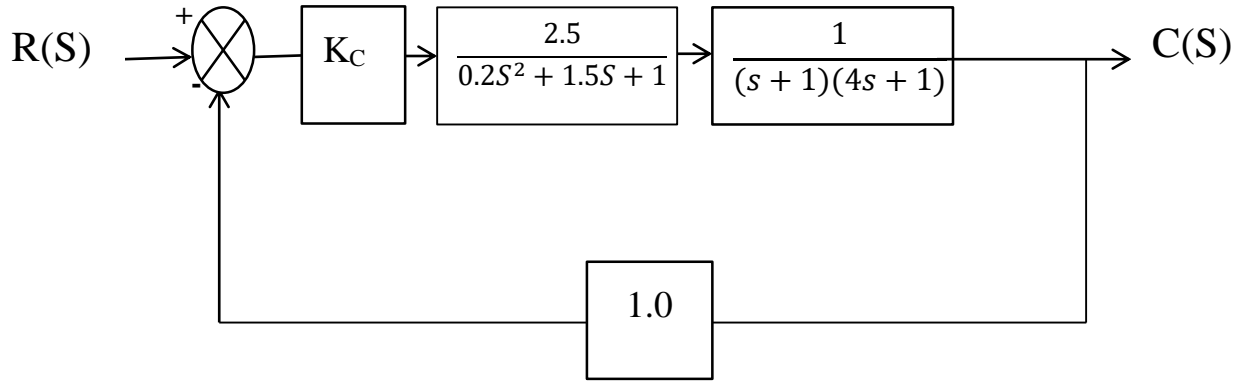

Figure 2: Block diagram of loop 1

Tuning of loop 1:

$$1+OLTF = \frac{(0.2s^2 + 1.5s + 1)(s + 1)(4s + 1) + 2.5K_C}{(0.2s^2 + 1.5s + 1)(s + 1)(4s + 1)} \dots\dots\dots(13)$$

The characteristic equation is $1+OLTF=0$

The Characteristic equation of loop1 is:

$$(0.2s^2 + 1.5s + 1)(s + 1)(4s + 1) + 2.5K_C \dots\dots\dots(14)$$

$$0.8S^4 + 7S^3 + 11.7S^2 + 6.5S + 1 + 2.5K_C = 0 \dots\dots\dots(15)$$

Root Locus for Loop 1:

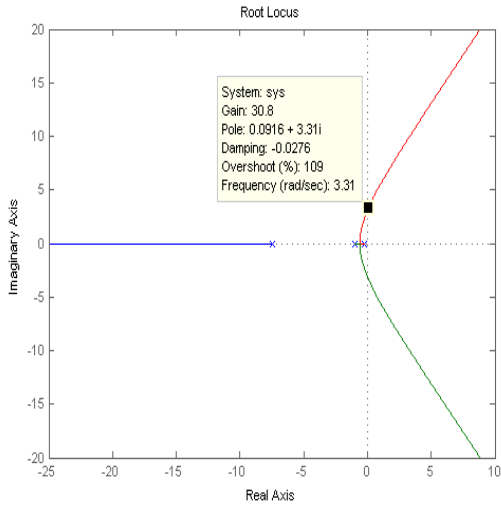

Figure 3: Root Locus for Loop1

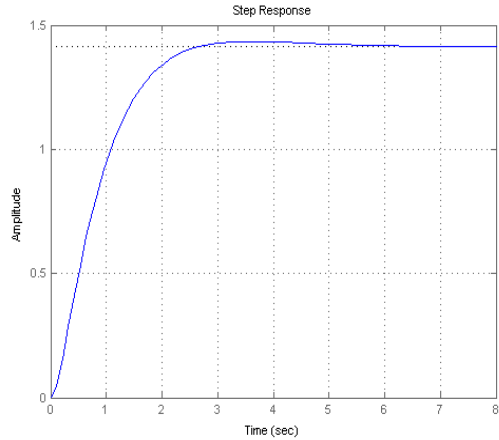

Figure 5: Step Response for Loop1

The Bode Plot Method:

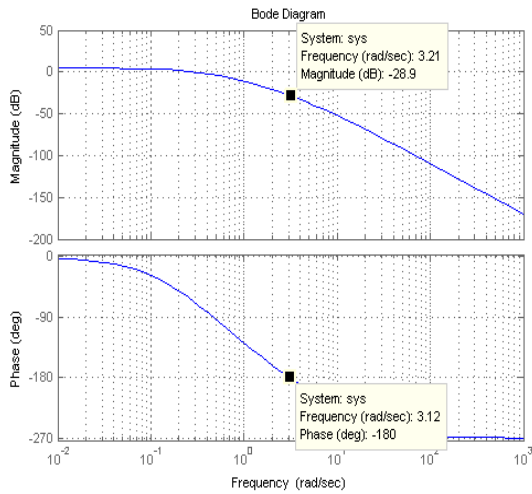

Figure 4: Bode Plot for Loop 1

Table 1: Values of Ultimate Gain (Ku) and Ultimate Period (Pu) for Loop 1

Method	Ku	Pu (sec)
Routh - Hurwitz	3.67	5.86
Root Locus	30.8	1.898
Bode	27.19	1.98

Loop2

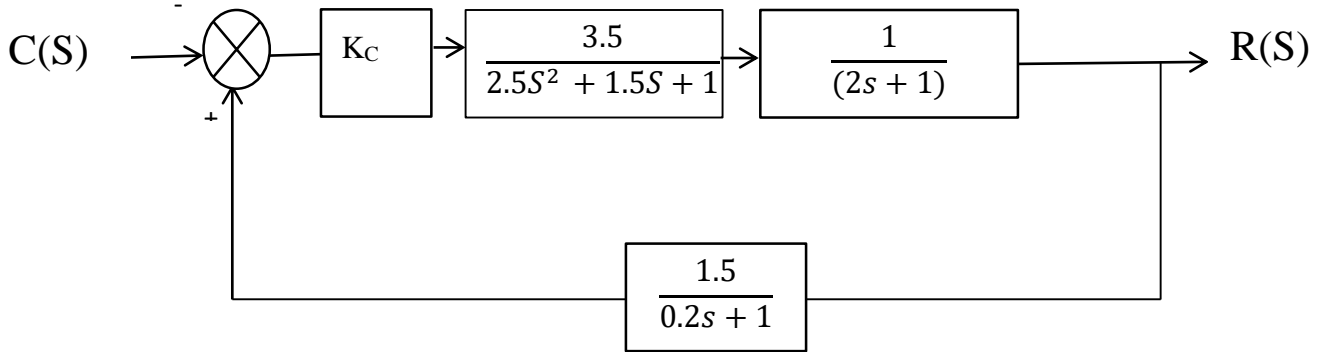

Figure 6: Block diagram for loop2

Tuning of loop 2:

$$1+OLTF = \frac{(2.5s^2+1.5s+1)(2s+1)(0.2s+1)+5.25K_C}{(2.5s^2+1.5s+1)(2s+1)(0.2s+1)} \dots\dots\dots(16)$$

Root Loucs Method:

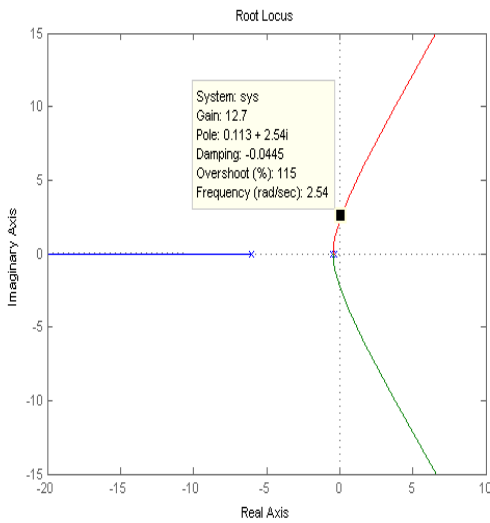

Figure 7: Root Locus for Loop 2

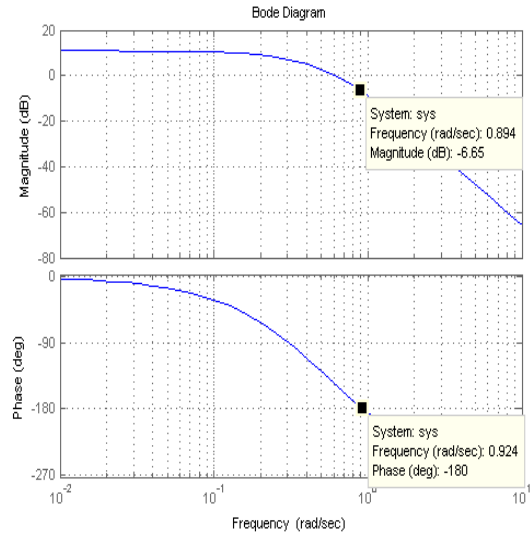

Figure 8: Bode plot for Loop 2

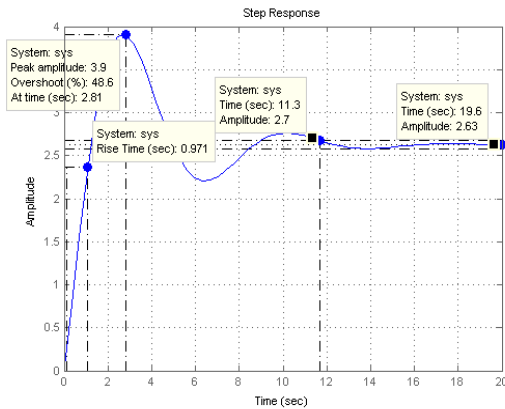

Figure 9: Step Response for Loop 2

Table 2: Values of Ultimate Gain (Ku) and Ultimate Period (Pu) for Loop 2

Method	Ku	Pu (sec)
Routh - Hurwitz	2.07	3.63
Root Locus	12.7	2.47
Bode	4.88	6.799

Cascade control

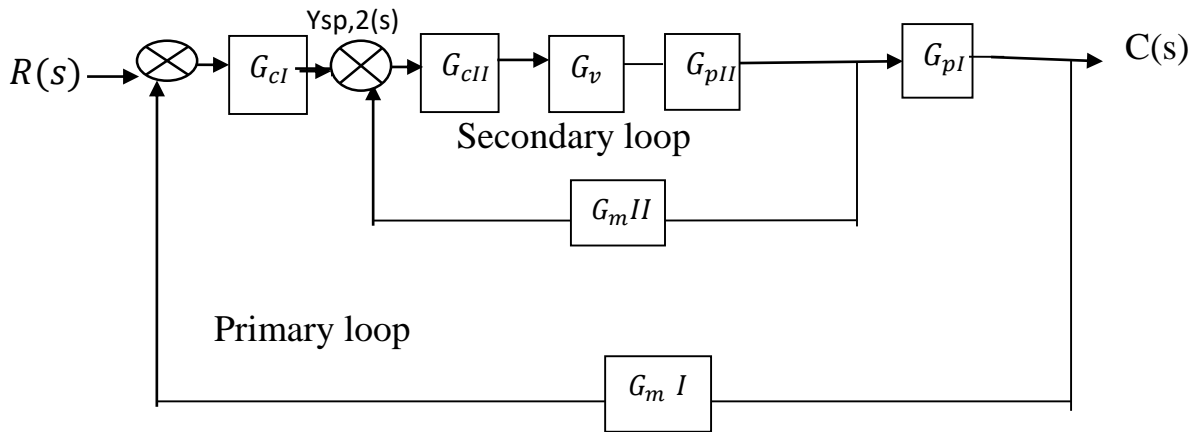

Figure 10: Block Diagram for Cascade Control

$$1+OLTF= \frac{(0.9S+1)(0.917S+1)(2S+1)+12.15K_{cII}}{(0.9S+1)(0.917S+1)(2S+1)} \dots\dots\dots(17)$$

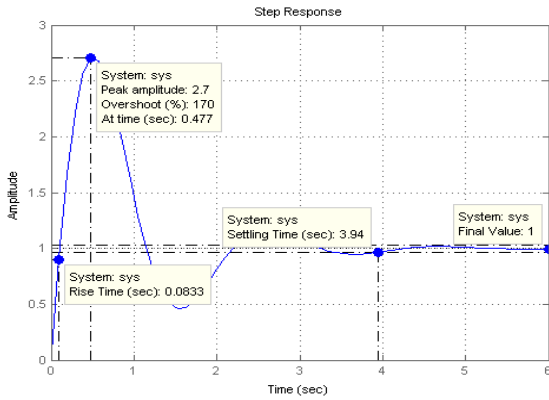

Figure 11: Response for Secondary Loop

Root Locus Method:

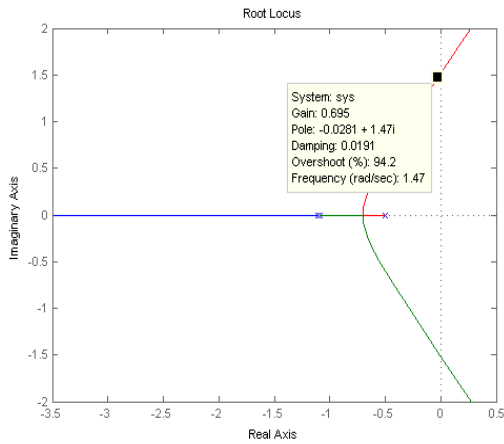

Figure 12: Root Locus for Secondary Loop

The Bode Plot Method:

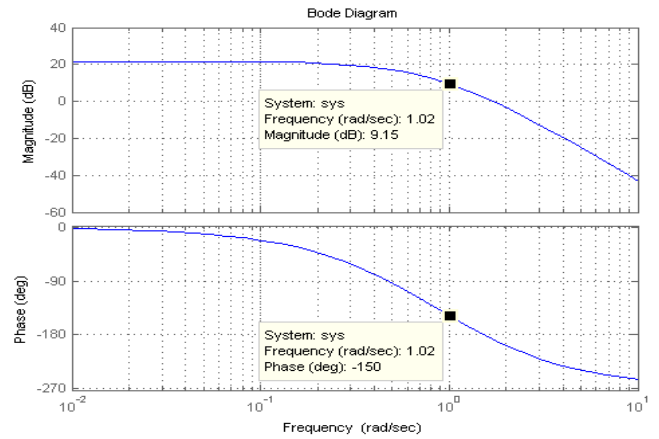

Figure 13: Bode Plot for secondary loop

Table 3: Values of Ultimate Gain (Ku) and Ultimate Period (Pu) for Secondary Loop

Method	Ku	Pu (sec)
Routh - Hurwitz	0.764	4.142
Root Locus	0.696	4.27
Bode	0.929	6.159

Outer Loop (Primary Loop):

The Characteristic equation of outer loop (primary loop)

$$1 + \left[\frac{GcIGcIIGVGpIIGpIGmI}{1 + GcIIGvGpIIGmII} \right] = 0 \dots\dots\dots(18)$$

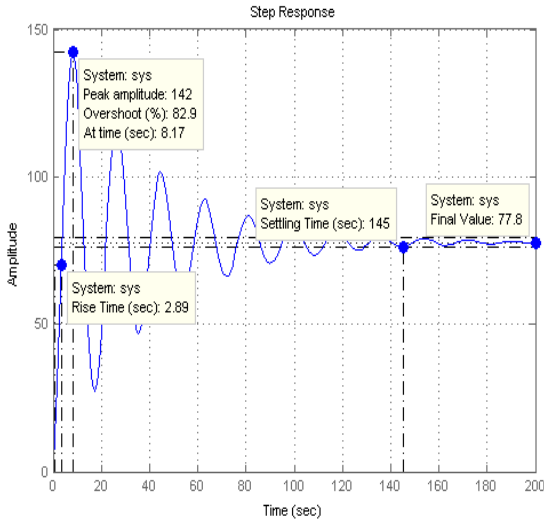

Figure 14: Step Response for Primary Loop

Root Locus Method:

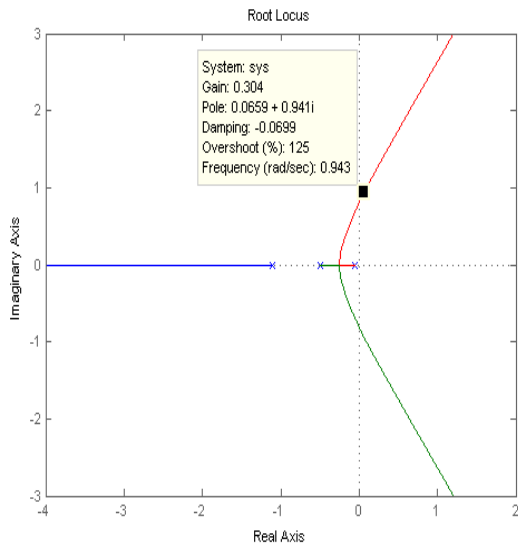

Figure 15: Root Locus for Primary Loop

The Bode Plot Method:

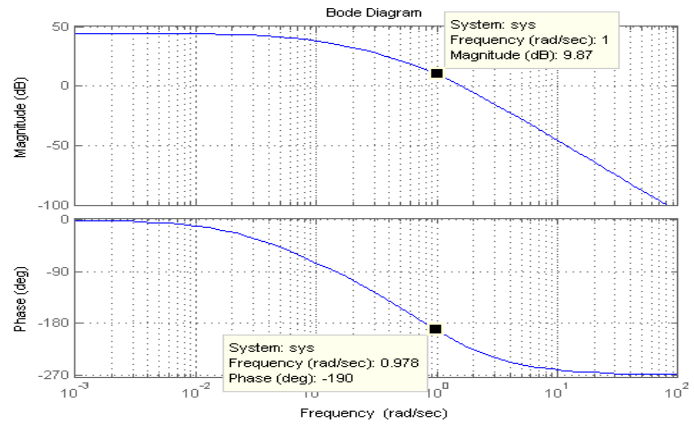

Figure 16: Bode Plot for Primary Loop

Table 4: Values of Ultimate Gain (Ku) and Ultimate Period (Pu) for Primary Loop

Method	Ku	Pu (sec)
Routh - Hurwitz	0.320	5.555
Root Locus	0.304	6.662
Bode	1.565	6.425

Table 5: Average Values of Ultimate Gain (Ku) and Ultimate Period (Pu) for Loops 1to 4

	Ku _(av)	Pu _(av) sec
Loop1	20.55	3.246
Loop2	6.55	4.299
Loop3	0.769	4.857
Loop4	0.534	6.214

Table 6: Using Ziegler – Nichols’ method to tuning parameters by using Ku (average) and Pu (average)

Type of Controller	Kc	τ_I (sec)	τ_D (sec)
P	3.55	-	-
PI	3.195	3.88	-
PID	4.26	2.33	0.58

III. Conclusion and Recommendation

From this study it's proved that Routh array, Root locus and Bode method give almost equal ultimate gains and ultimate periods therefor, the average was taken for the loop simulation. It is concluded that any method of the can be selected and use confidently for tuning and stability analysis. Further work is recommended to be carried out to transfer the control system to digital ad SCADA systems.

- [6] Manfred Morari; N. Lawrence Ricker "Model Predictive Control Toolbox User's Guide for Use with MATLAB", The Math Works, 1998.

References

- [1] Gasmelseed, G.A. "Advanced control for graduate students", third edition G-town, Khartoum, 2016.
- [2] Norman S. Nise,"control system engineering", sixth edition, Asia, John Wiley and sons, 2011.
- [3] Stephanopoulos, G., "Chemical process control, an introduction to theory and practice", Prentice Hall of India Private limited, New Delhi, 2005.
- [4] Erol I., 'kinetics of esterification of ethyl alcohol by acetic acid on a catalytic resin', journal of engineering sciences, Vol. 8, No. 1, 2002. pp(109- Erol I., 'kinetics of esterification of ethyl alcohol by acetic acid on a catalytic resin', journal of engineering sciences, Vol. 8, No. 1, 2002. pp(109-113), Istanbul.
- [5] Roland S., "Advanced control engineering", Butterworth-Heinemann, Oxford, 2001.